

# SEIFERT ISOVOLT



## Three-Phase Primary Interlock Switch for ISOVOLT HS

### Application

A primary interlock switch is used in radiation protection cabinets and rooms in conjunction with doors and flaps that can be opened under regular operative conditions, if the power supply of the X-ray radiating unit must be interrupted in the primary current circuit and if this disconnection through an interlock circuit must be physically linked to said doors and flaps.

The primary interlock switch consists of two components which are designed in such a way that only one of them needs wiring. This component is usually mounted to the non movable part of the cabinet. The second component of the primary interlock switch is attached to the door or flap and does not need any electrical connections.

The switch is wired in such a way that upon opening it directly interrupts the primary current circuit of the X-ray equipment. An additional internal switch is available for status messages to the control.

- Produced under ISO 9001 certified quality management system

GE imagination at work



### Technical Data

Main contactors	Maximum 400 V AC, maximum 16 A
Auxiliary switch	Maximum 250 V AC, maximum 3 A
Overtravel main contactors	8 mm (see Figure 1 / A)
Overtravel auxiliary switch	Setting range 1 - 5 mm (see Figure 1 / B), Factory setting 3 mm / 0.12"
Differential auxiliary switch	0.5 mm (see Figure 1 / C)
Dimensions	See drawing

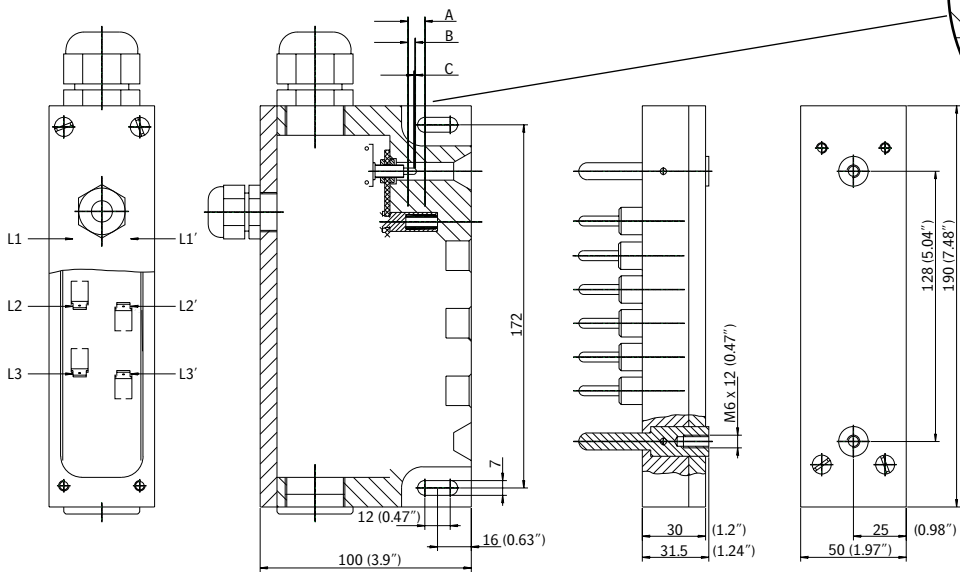

Fig. 1 Main dimensions of primary interlock switch



Fig. 2 Primary interlock switch, dismounted