

SEIFERT ERESKO 32 MFC3.1



Portable X-ray Unit 200 kV Panoramic Tube Head, air cooled

Overview

The ERESKO 32 MFC3.1 is a 200 kV constant potential portable X-ray tube head using state of the art switching technology with high radiation output allowing shortest exposure times thereby increasing productivity.

GE Inspection Technologies uses the number 32 to identify the superior penetration performance of its portable X-ray unit line.

This means the ERESKO 32 MFC3.1 is capable of penetrating 32 mm (1.26") Fe with a 2.0 density after a ten-minute exposure using AGFA STRUCTURIX D7 film @ 700 mm (27.5") FFD.

The X-ray tube head consists of a sturdy metal-ceramic X-ray tube and high voltage generator integrated into a rugged compact housing. The air-cooled 200 kV / 600 W end-grounded X-ray tube is thermally protected for extended life.

The high voltage generator generates high-stability constant potential voltage at higher efficiency than conventional line frequency equipment.

The performance of the X-ray tube and the high voltage generator are continuously monitored for protection and operational safety. The flexible connecting cable is heavy-duty and light weight.

Additional Features

- Rugged construction with proven reliability
- DC voltage operation
- End-grounded, metal-ceramic X-ray tube
- Large 40° x 360° emergent beam
- Modern power electronics provides high stability
- Gas insulated high voltage section reduces size & weight
- 100% duty cycle at 30° Celsius (86° F)
- EMC - certified under EN 55011 / IEC 801 (electromagnetic compatibility)
- Water resistant in accordance with protection class IP65
- Produced under ISO 9001 certified quality management system

Standard Delivery Scope of complete X-ray unit

See product information Digital Control "ERESKO MF3 control"

GE imagination at work



ERESCO 32 MFC3.1

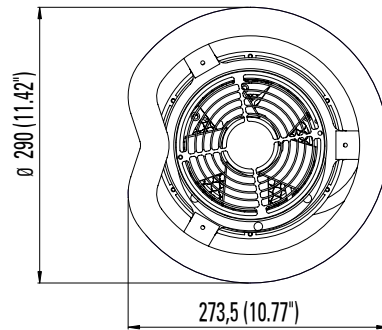
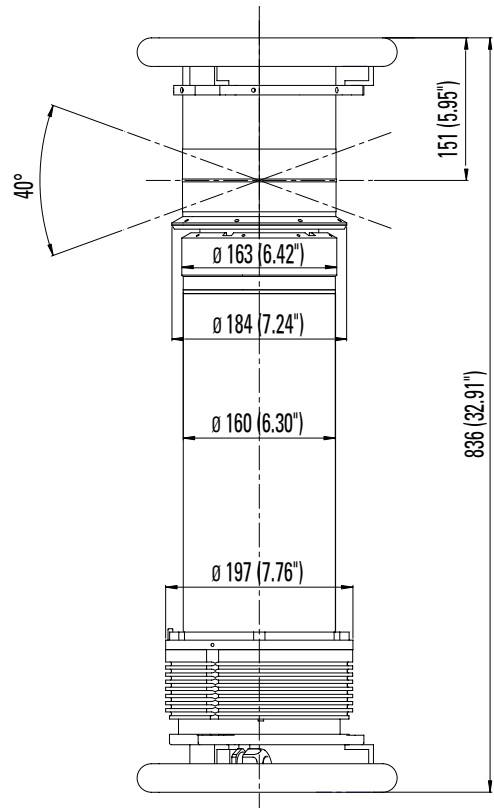
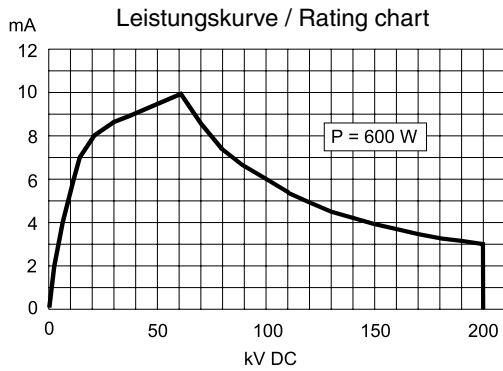
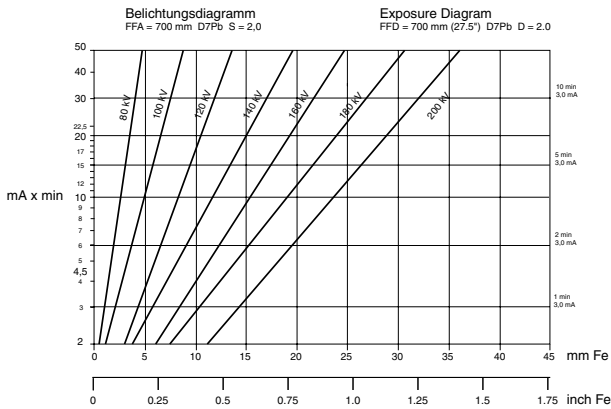

drawings not true to scale

Technical Data

X-ray tube type	200 kV metal-ceramic with Tungsten (W) anode
Target angle	22°
Inherent filtration	0.4 mm Fe/Ni/Co + 2 mm Al
Emergent beam	40° x 360°
Focal spot size (en 12 543)	0.4 x 4.0 mm
Tube current	0.5 - 10 mA (3.0 mA /200 kV)
Current and voltage stability *)	± 1%
Continuous rating	600 W
Duty cycle (θ _{amb} = 30° C)	100%
Power input, max. *)	1.0 kVA
Weight of tube head	31 kg (68.3 lbs)
Protection class	IP65
kV range	5 - 200 kV (acc. to rating chart)

*) connected to control

Options

- Carrying cradle
- Laser centering device
- Diaphragm caps
- Fail-safe flashing warning lamps
- Stands and mounting kits
- Aluminium transport box